

HydroSure™

IRRIGATION SYSTEMS THAT WORK

200m Heavy Duty Hose Reel Pull Cart with Swivel Wheels

www.hydrosure.com

100205219





5 055936 405219 >

COMPONENTS INCLUDED

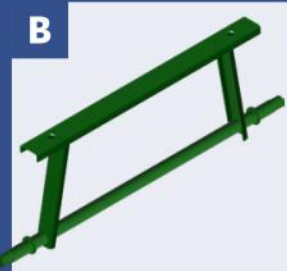

A 

B 

C 

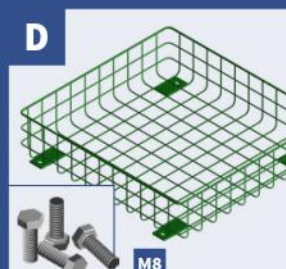
D 
M8

E 
Ø12 M12

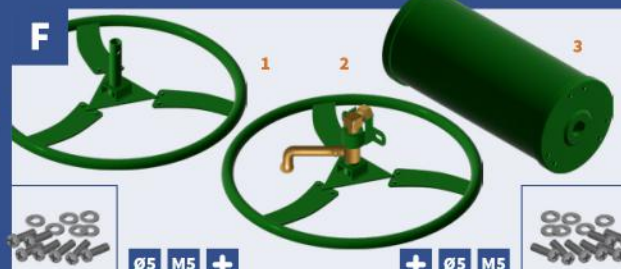
F 
Ø5 M5 + + Ø5 M5

G 
Ø6 M6

H 
+ Ø6 M6

I 
+ Ø6 M6

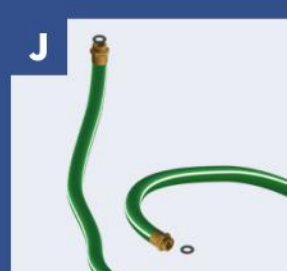
J 

ASSEMBLY INSTRUCTIONS

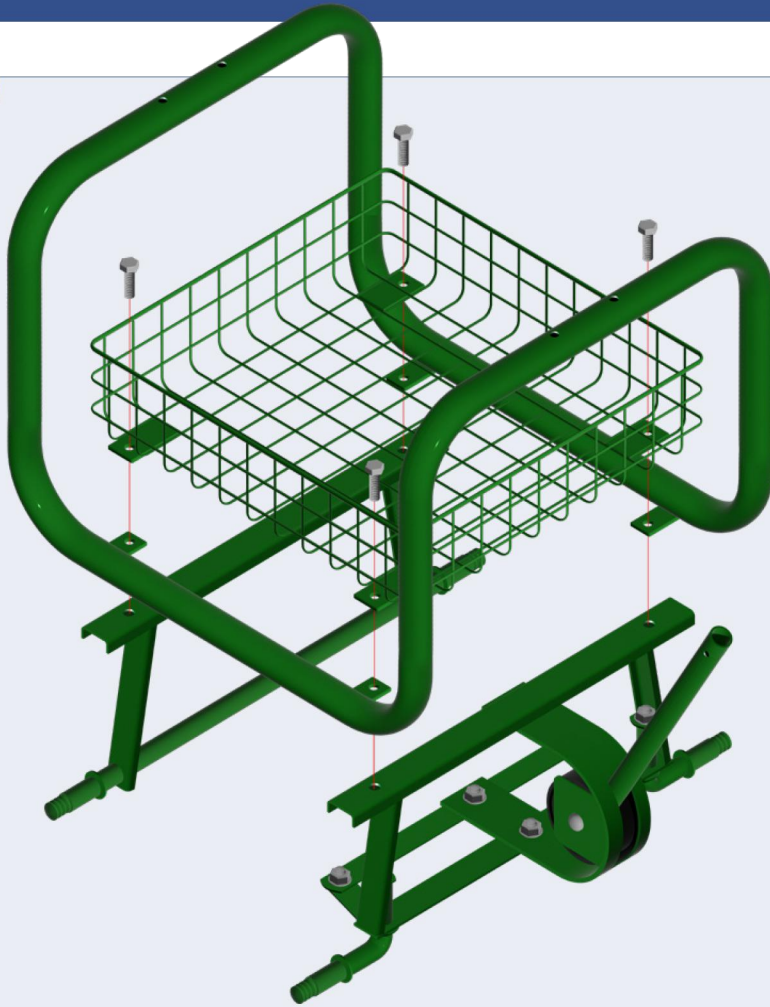

Tools Required



Adjustable Spanner

A

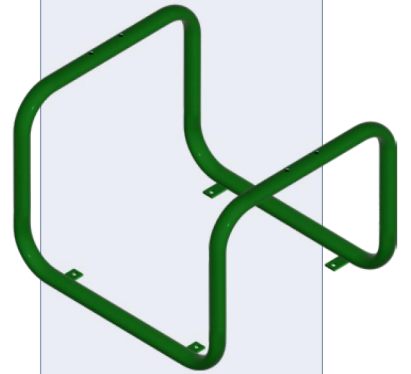

Place the Frame (A) on Top of Rear Axle (B) and Front Axle (C) and Align the Mounting Holes.
Lower the Mesh Basket (D) into the Frame (A) and Align the Mounting Holes.

B



C



D

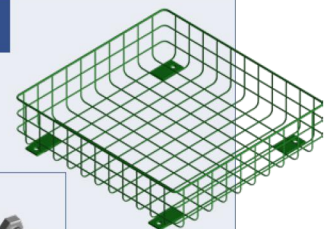

M8

Assembled



Secure Mesh Basket (D) to the Frame (A) and the Axles (B & C) using 4 x M8 Bolts.

ASSEMBLY INSTRUCTIONS



Tools Required



Adjustable Spanner

E



Attach Wheels (E) to the end of each Axle.

NOTE: Ensure the Valve is Facing Outwards and the Long Mount Facing Inwards.



E

VALVE

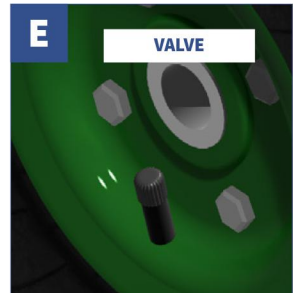

E

LONG MOUNT

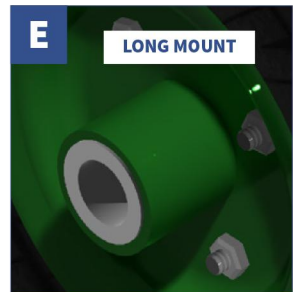

E

Ø12 M12

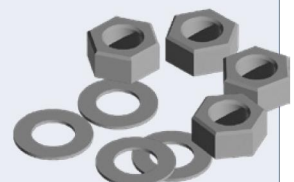

Secure the Wheels using Large M12 Nuts and Large Ø12 Washers.

ASSEMBLY INSTRUCTIONS

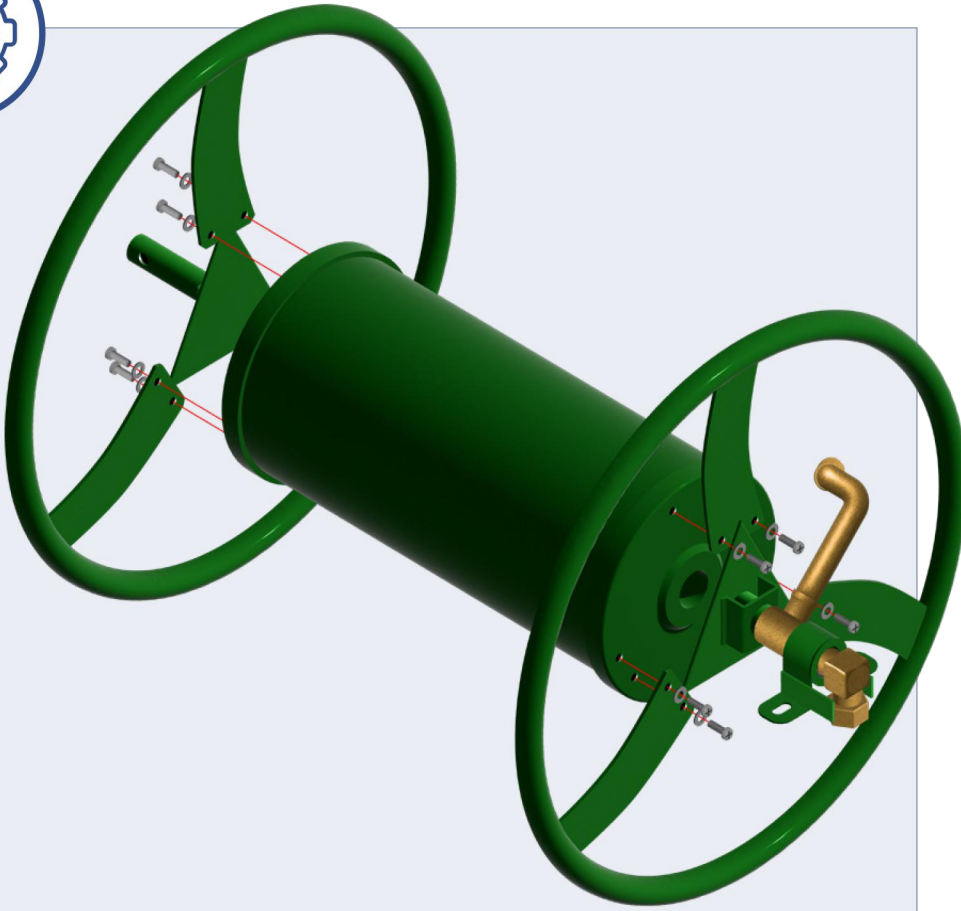

Tools Required



Cross Head Screwdriver

F

1



Connect Spool Ends (F 1 & F2) to either end of the Spool Drum (F3) with M5 Screws and Ø5 Washers using the Cross head Screwdriver.

F

2

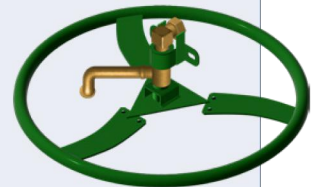

Assembled

F

3

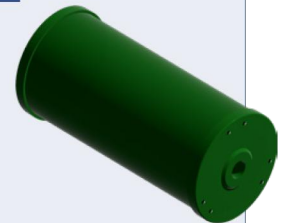

F

Ø5 M5 +



Securely tighten all 12 Screws. +

ASSEMBLY INSTRUCTIONS

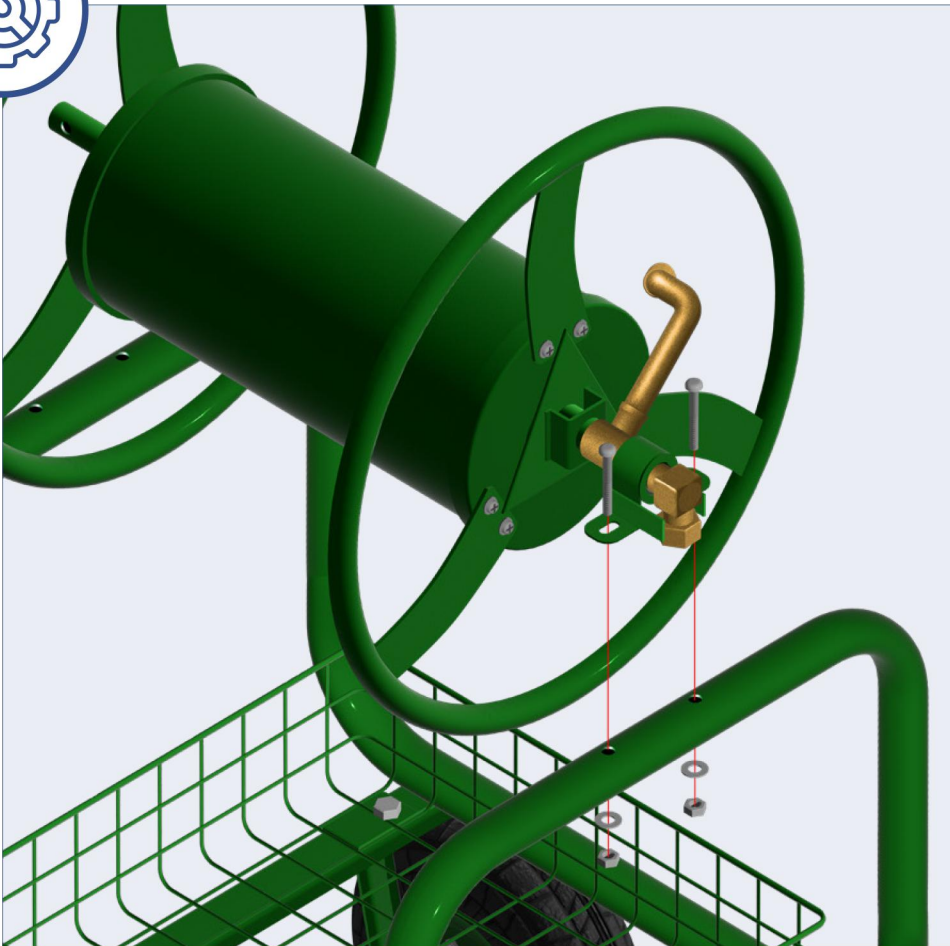

Place Assembled Hose Drum (F) onto the Frame.
Ensure the Brass Valve with Bearing Bracket is on the same side as Front Axle (C).

Tools Required



Adjustable Spanner



Assembled

G

Ø6 M6

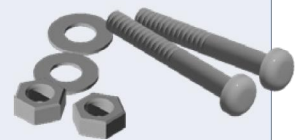

Secure the Bearing Bracket using M6 Bolts, Ø6 Washers and M6 Nuts (G).

ASSEMBLY INSTRUCTIONS

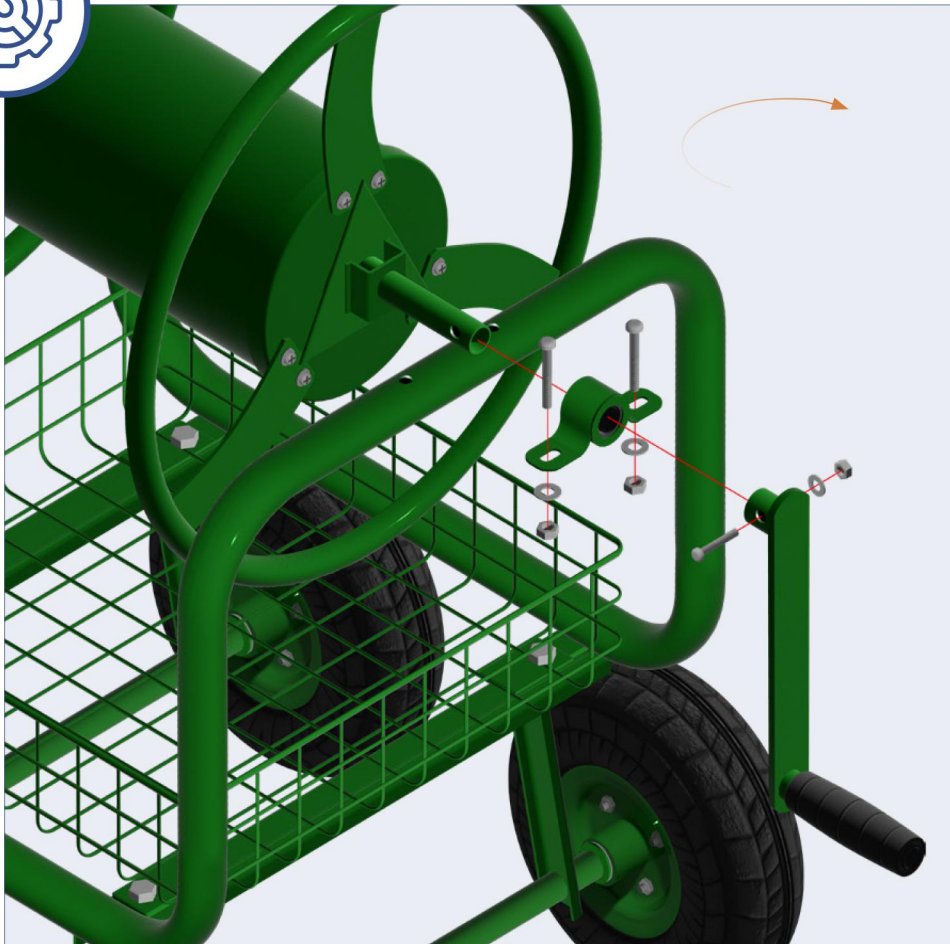

Tools Required

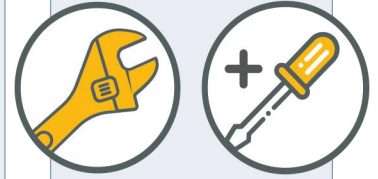

Adjustable Spanner & Cross Head Screwdriver

G

Ø6 M6



At the Rear of the Cart above Axle (B). The Drum Shaft will be resting on top of the Frame. Slide Bearing Bracket (G) onto the Drum Shaft and Align with the Two Holes on the Frame. Secure with M6 Bolts, Ø6 Washers and M6 Nuts (G).



H

Ø6 M6 +



Slide the Winder Handle (H) onto the Axle Shaft.

Secure with M6 Screw, Ø6 Washer and M6 Nut (H) using the Adjustable Spanner and Cross head Screwdriver.

ASSEMBLY INSTRUCTIONS

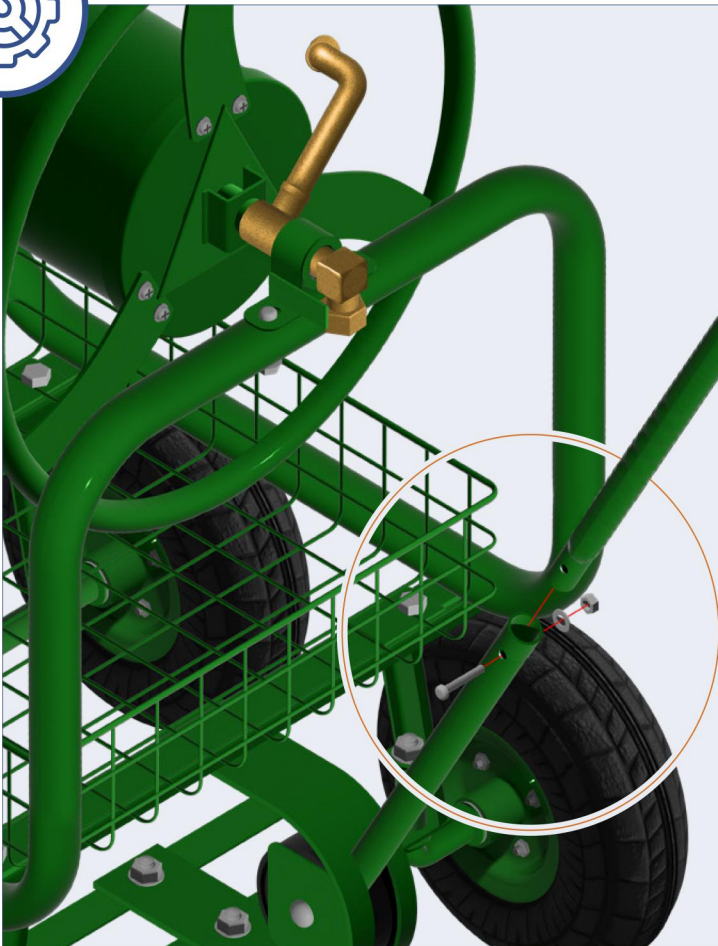

Tools Required



Adjustable Spanner &
Cross Head Screwdriver

I

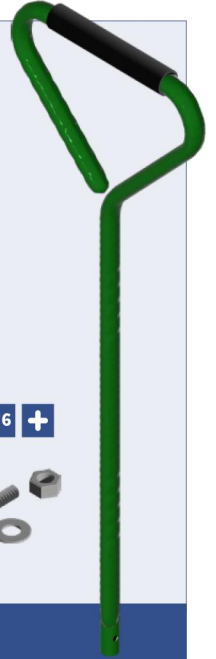

Ø6 M6 +



Working on the Front of the Cart above Axle (C). Insert Pull Handle (I) into the Axle Steering Shaft. Secure with M6 Screw, Ø6 Washer and M6 Nut (I) using the Adjustable Spanner and Cross head Screwdriver.

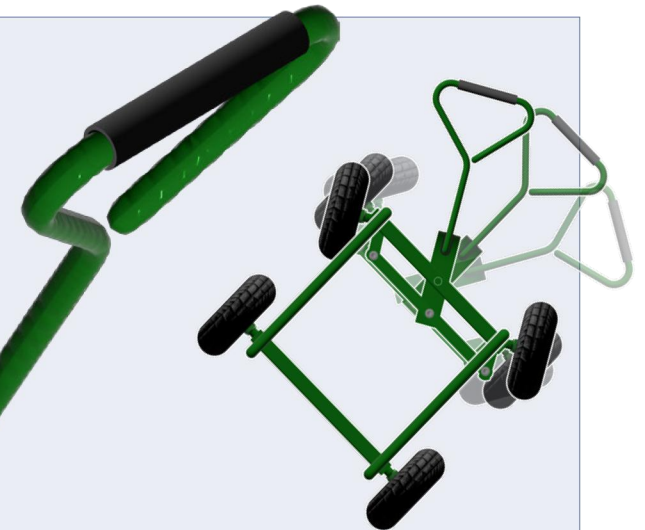

J

Attach Leader Hose (J) to the Brass Valve Outlet. Do not overtighten.

200M HEAVY DUTY HOSE REEL CART WITH BASKET

COMPLETE ASSEMBLY



ADDITIONAL EQUIPMENT



ADDITIONAL EQUIPMENT

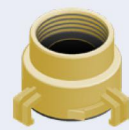

ADDITIONAL EQUIPMENT

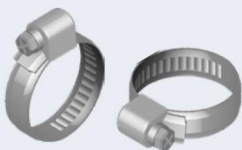

HydroSureTM

IRRIGATION SYSTEMS THAT WORK

www.hydrosure.com

