

JetInox 102M Product Specifications

Materials

N°	PARTS *	MATERIALS
1	PUMP BODY	AISI 304 STAINLESS STEEL X5 CRNi 1810 - UNI 6900/71
4	IMPELLER	TECHNOPOLYMER A
7	SHAFT WITH ROTOR	AISI 416 STAINLESS STEEL X12 CrS13 - UNI 6900/71
16	MECHANICAL SEAL	CARBON/CERAMIC
28	OR GASKET	NBR RUBBER
36	SEAL HOLDER COVER	AISI 304 STAINLESS STEEL X5 CRNi 1810 - UNI 6900/71
160	VENTURI DIFFUSER NOZZEL GROUP	TECHNOPOLYMER A

* In contact with liquid

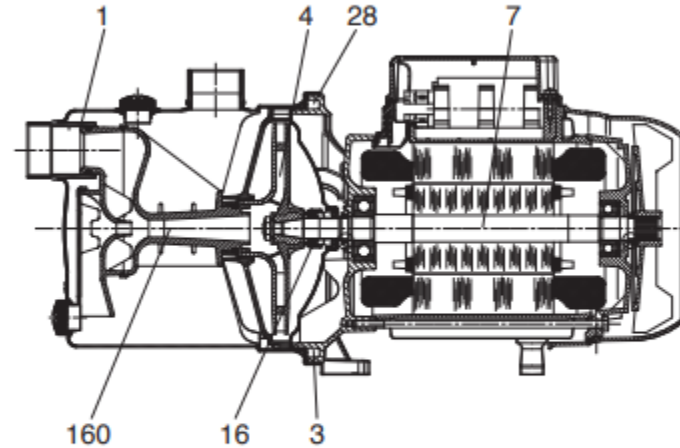

Performance Range

The performance curves are based on kinematic viscosity values = 1 mm²/s and density equivalent to 1000 kg/m³. Curve tolerance according to ISO 9906.

GRAPHIC SELECTION TABLE

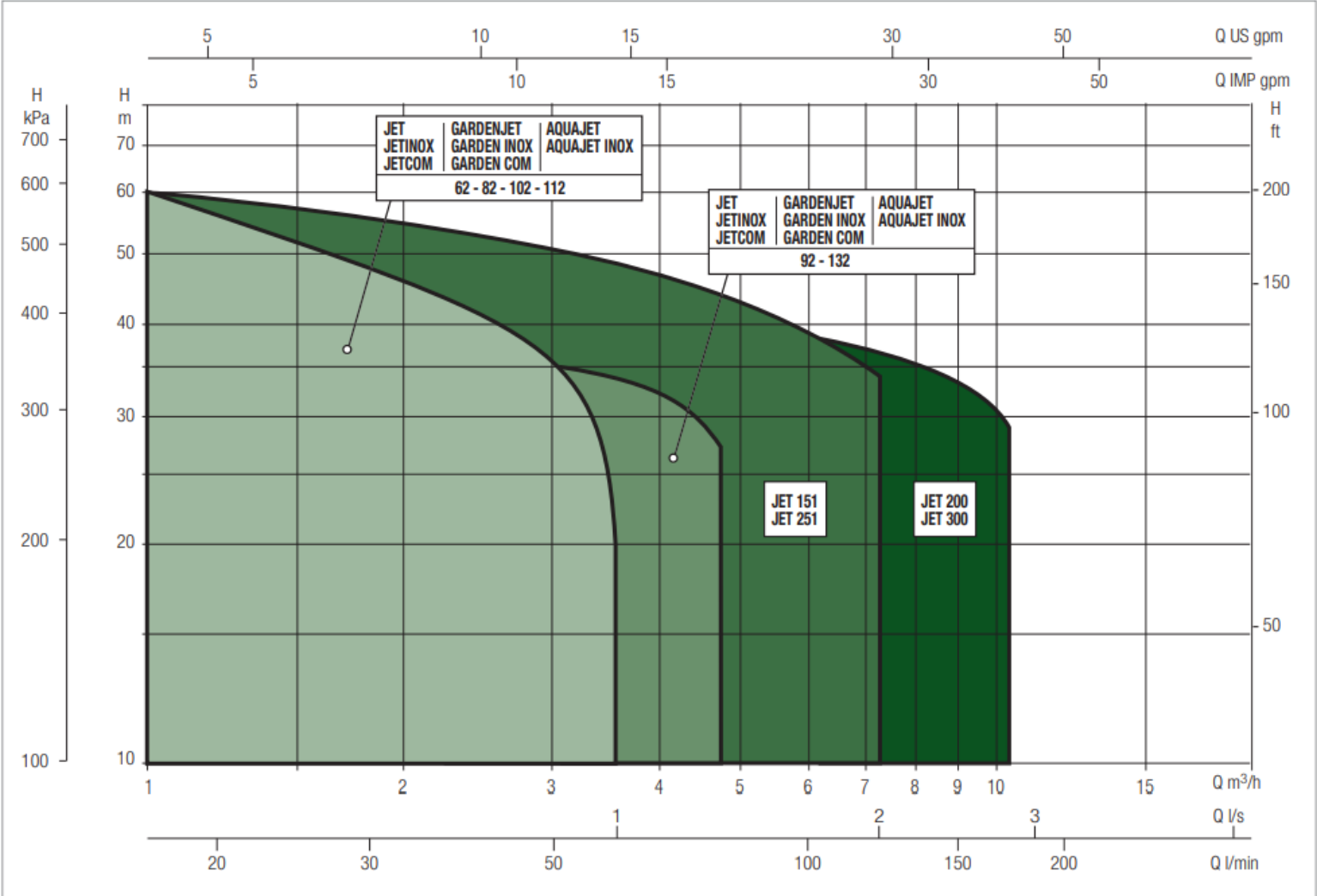

Self-Priming Capacity

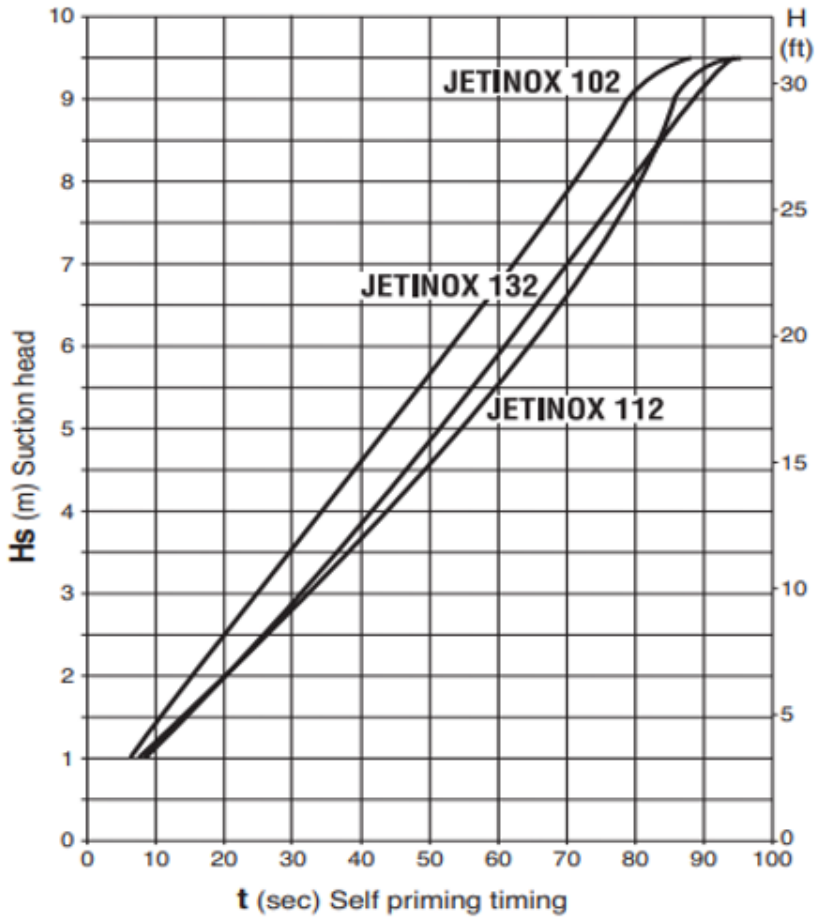
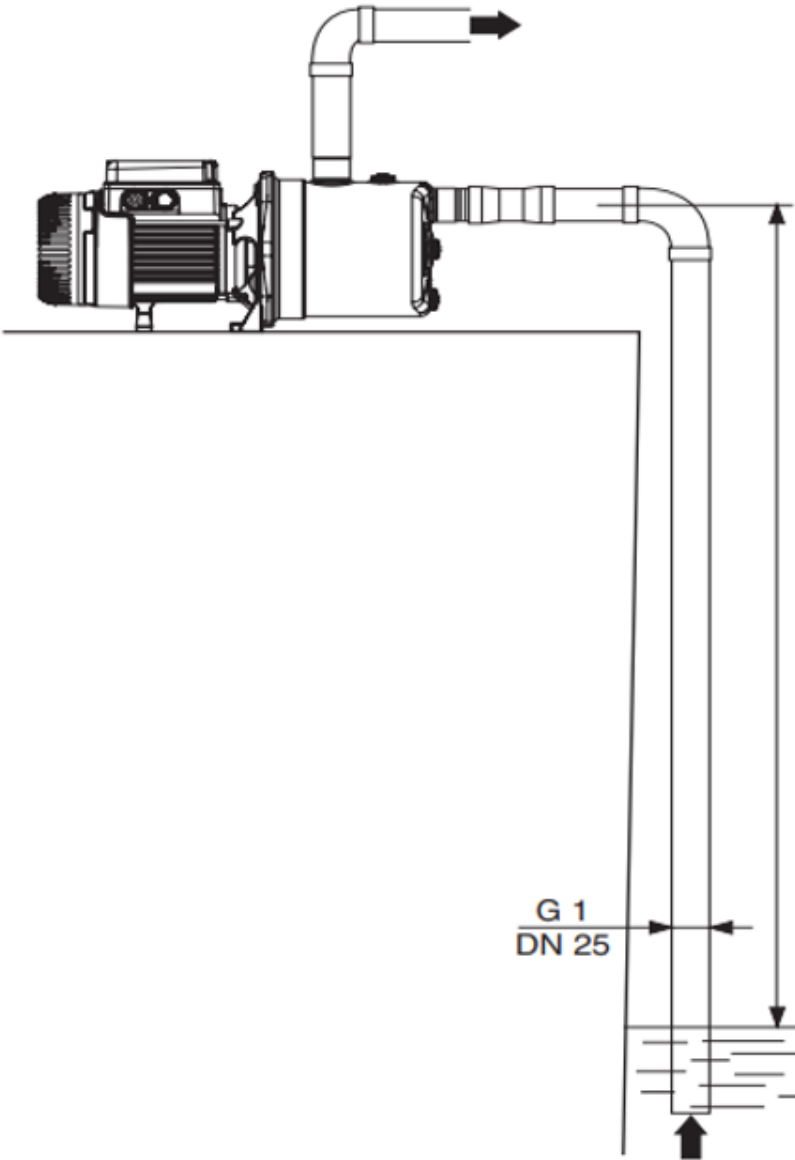

Dimensions & Performance Curves

JETINOX 102 - SELF-PRIMING CENTRIFUGAL ELECTRIC PUMPS FOR DOMESTIC WATER SUPPLY

Liquid temperature range pumped: from 0 °C to +35 °C - Maximum ambient temperature: +50°C

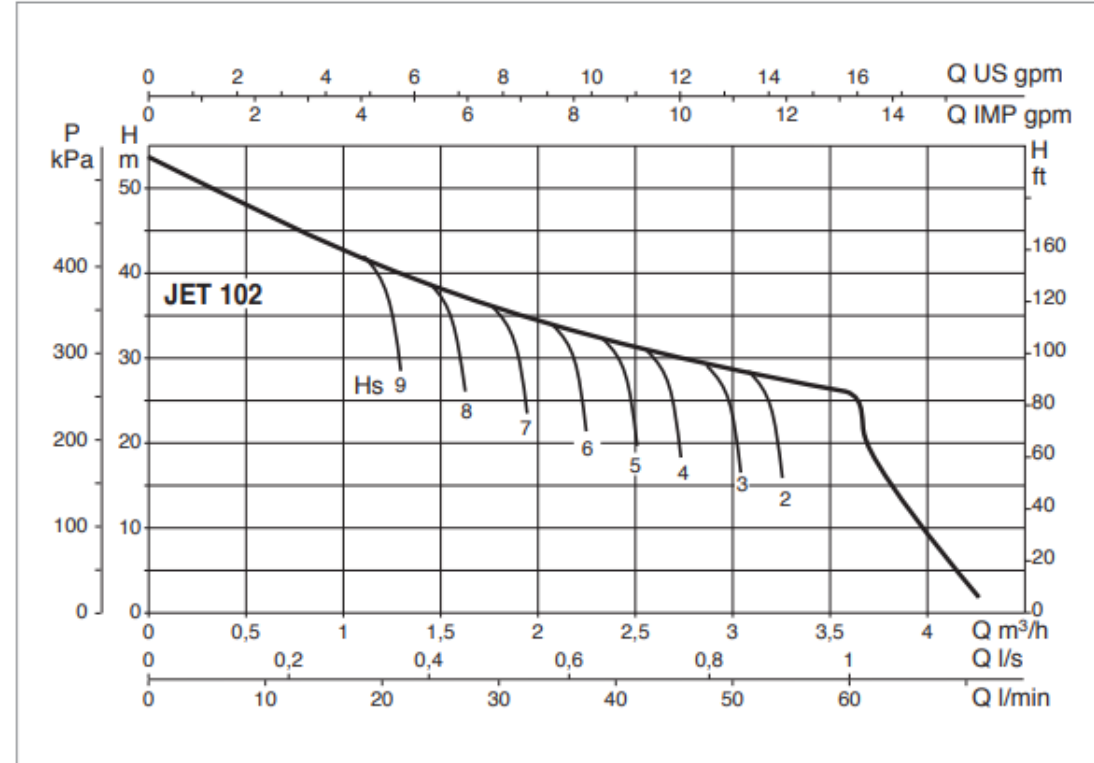
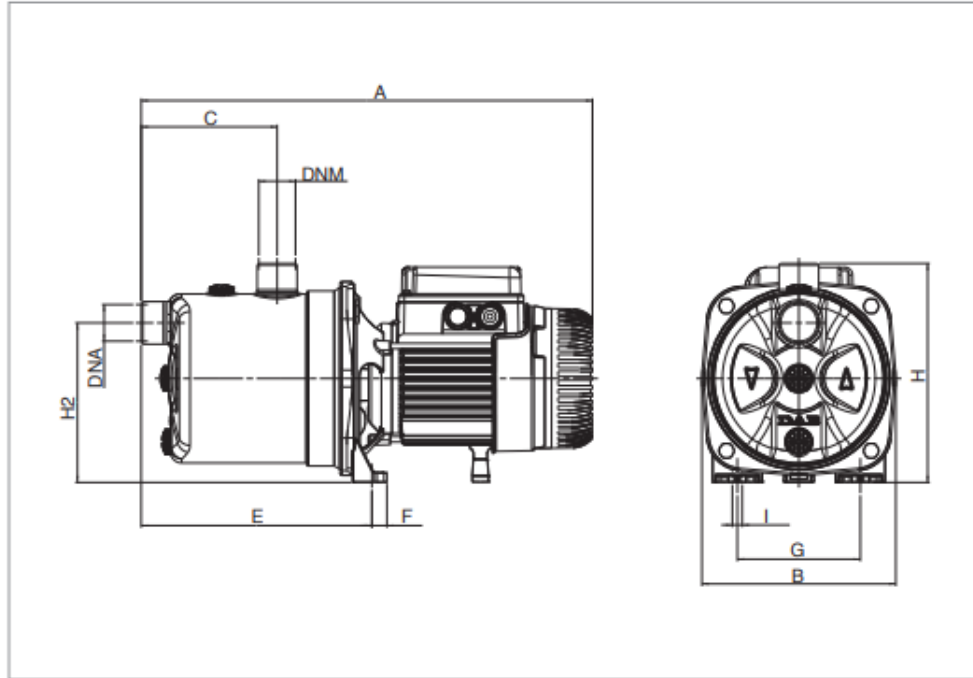

The performance curves are based on the kinematic viscosity values = 1 mm²/s and density equivalent to 1000 kg/m³. Curve tolerance according to ISO 9906.

Model	A	B	C	E	F	G	H	H1	H2	I Ø	L	DNA GAS	DNM GAS	Pack Dimensions			Volume (MC)	Gross Weight Kg
														L/A	L/B	H		
JetInox 102M	424	174	122	207	14	111	197	-	144	9	-	1"	1"	470	240	240	0.027	9.7